

RENAULT

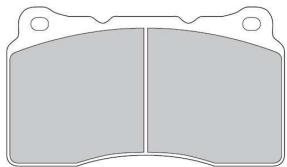

W131.8 × H77.2mm  
**i147**

Front:MEGANE II 2.0 RS

D300i=¥18,900 (税込)
D550i=¥23,100 (税込)
D750iL / D750i=¥28,350 (税込)

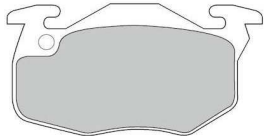

W105 × H54mm  
**i191**

Front:LUTECIA 1.4 RN BENDIX

D300i=¥16,800 (税込)
D550i=¥21,000 (税込)
D750iL / D750i=¥26,250 (税込)

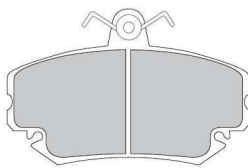

W105 × H64.5mm  
**i192**

Front:ALPINE/TWINGO, II / MEGANE/LUTECIA, II 注1

D300i=¥16,800 (税込)
D550i=¥21,000 (税込)
D750iL / D750i=¥26,250 (税込)

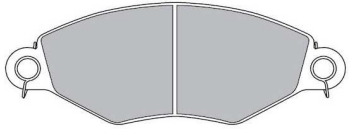

W131 × H47.5mm  
**i198**

Front:KANGOO

D300i=¥16,800 (税込)
D550i=¥21,000 (税込)
D750iL / D750i=¥26,250 (税込)

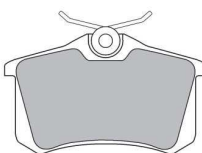

W87 × H53 × T14.70mm  
**i212**

Rear:Ground SCENIC

D300i=¥16,800 (税込)
D550i=¥21,000 (税込)
D750iL / D750i=¥26,250 (税込)

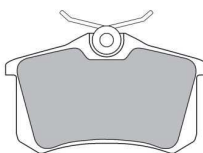

W87 × H53 × T16.70mm  
**i213**

Rear:SCENIC / Ground SCENIC / MEGANE II

D300i=¥16,800 (税込)
D550i=¥21,000 (税込)
D750iL / D750i=¥26,250 (税込)

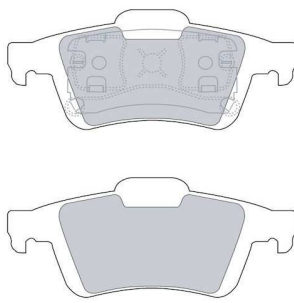

W123.0 × H51.9mm  
**i265**

Rear:MEGANE RS / MEGANE II RS TURBO / RAGUNA II 注2

D300i=¥16,800 (税込)
D550i=¥21,000 (税込)
D750iL / D750i=¥26,250 (税込)

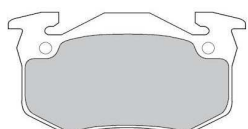

W105 × H55mm  
**i291**

Rear:MEGANECOUPÉ 2.0 16V / LUTECIA, II 注1

D300i=¥16,800 (税込)
D550i=¥21,000 (税込)
D750iL / D750i=¥26,250 (税込)

RENAULT

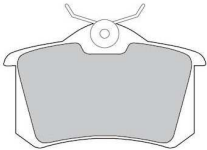
 W86.8 × H53mm <b>i292</b>
Rear:MEGANE II RS
D300i=¥16,800 (税込)
D550i=¥21,000 (税込)
D750iL/D750i=¥26,250 (税込)

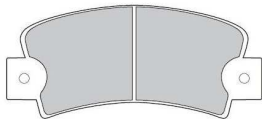
 W109 × H47.5mm <b>i302</b>
Rear:VINGT CING R25 3.0 V6
D300i=¥16,800 (税込)
D550i=¥21,000 (税込)
D750iL/D750i=¥26,250 (税込)

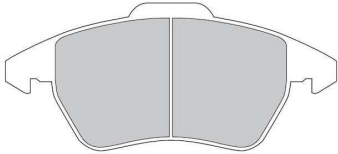
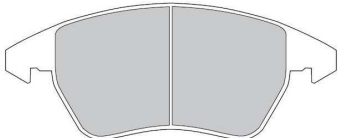
 W156.4 × H71.4mm  W156.4 × H66mm <b>i316</b>
Front:RAGUNA II WAGON 2.0 16V
D300i=¥16,800 (税込)
D550i=¥21,000 (税込)
D750iL/D750i=¥26,250 (税込)

 W156 × H70mm <b>i318</b>
Front:Ground SCENIC/RAGUNA II 3.0 V6
D300i=¥16,800 (税込)
D550i=¥21,000 (税込)
D750iL/D750i=¥26,250 (税込)

 W126 × H58.5mm <b>i2101</b>
Rear:VINGT TIAN/SAFRANE
D300i=¥18,900 (税込)
D550i=¥23,100 (税込)
D750iL/D750i=¥28,350 (税込)

**注1:** 現車のパッド形状にてご確認をお願いします。

**注2:** リテーナー形状が2種類ありますので、プレート背面取付リテーナーのみの設定になります。(現車パッド形状を予めご確認下さい)