

PORSCHE

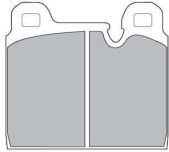

W76.6 × H70mm  
**i150**

PORSCHE 911 注1

D300i=¥18,900 (税込)

D550i=¥23,100 (税込)

D750iL / D750i=¥28,350 (税込)

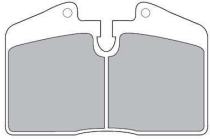

W97.8 × H65.5mm  
**i151**

PORSCHE 911/928/944/968

D300i=¥18,900 (税込)

D550i=¥23,100 (税込)

D750iL / D750i=¥28,350 (税込)

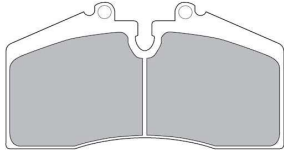

W131.8 × H71mm  
**i152**

PORSCHE 911/928

D300i=¥18,900 (税込)

D550i=¥23,100 (税込)

D750iL / D750i=¥28,350 (税込)

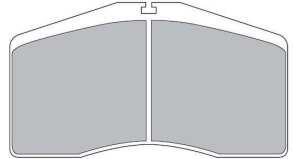

W131.8 × H71mm  
**i153**

PORSCHE 911/928 注1

D300i=¥18,900 (税込)

D550i=¥23,100 (税込)

D750iL / D750i=¥28,350 (税込)

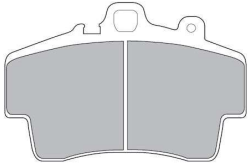

W114 × H78mm  
**i159**

PORSCHE BOXSTER 注1

D300i=¥18,900 (税込)

D550i=¥23,100 (税込)

D750iL / D750i=¥28,350 (税込)

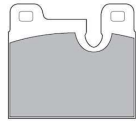

W61.5 × H56.5mm  
**i251**

Rear:PORSCHE 911 (3.2L)

D300i=¥16,800 (税込)

D550i=¥21,000 (税込)

D750iL / D750i=¥26,250 (税込)



W63.8 × H65mm  
**i252**

Rear:PORSCHE 911Carrera2

D300i=¥16,800 (税込)

D550i=¥21,000 (税込)

D750iL / D750i=¥26,250 (税込)



W112.3 × H73.2mm  
**i254**

Rear:PORSCHE 911/BOXSTER 注1

D300i=¥18,900 (税込)

D550i=¥23,100 (税込)

D750iL / D750i=¥28,350 (税込)

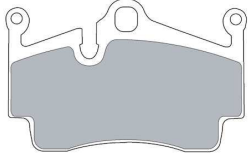

W112.3 × H73.0 × T15.3mm  
**i255**

Rear:PORSCHE CAYMAN (2.7L)

D300i=¥18,900 (税込)

D550i=¥23,100 (税込)

D750iL / D750i=¥28,350 (税込)



W121.2 × H86.5mm  
**i257**

Rear:PORSCHE 911GT2(996) 注1

D300i=¥18,900 (税込)

D550i=¥23,100 (税込)

D750iL / D750i=¥28,350 (税込)

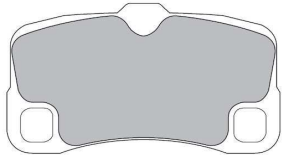

W127.8 × H75.3  
**i258**

Rear:PORSCHE 911GT3 Cup (997) 注1

D300i=¥23,100 (税込)

D550i=¥27,300 (税込)

D750iL / D750i=¥32,550 (税込)

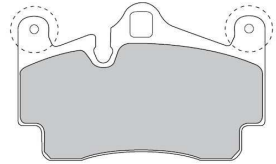

W112xH73xT16.7mm  
**i259**

Rear:PORSCHE BOXSTER (2.7L-987)

D300i=¥23,100 (税込)

D550i=¥27,300 (税込)

D750iL / D750i=¥32,550 (税込)

PORSCHE

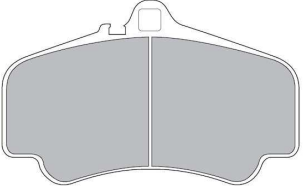
 W140×H88.5mm <b>i350</b>
Front:PORSCHE 911GT2,3 (996)/Turbo4 (996) 注1
D300i=¥18,900 (税込)
D550i=¥23,100 (税込)
D750iL/D750i=¥28,350 (税込)

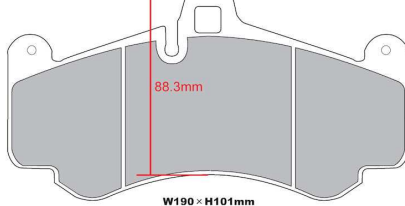
 W190×H101mm <b>i351</b>
Front:PORSCHE 911GT2,3 (996-6pot) 注1
D300i=¥23,100 (税込)
D550i=¥27,300 (税込)
D750iL/D750i=¥32,550 (税込)

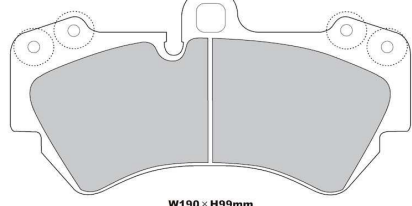
 W190×H99mm <b>i352</b>
Front:PORSCHE CAYENNE (3.2L)
D300i=¥23,100 (税込)
D550i=¥27,300 (税込)
D750iL/D750i=¥32,550 (税込)

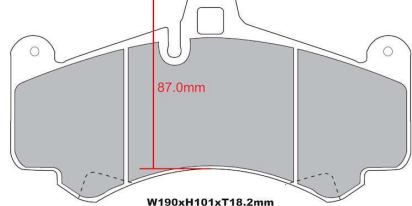
 W190×H101×T18.2mm <b>i354</b>
Front:PORSCHE 911GT3 Cup (997) 注1
D300i=¥23,100 (税込)
D550i=¥27,300 (税込)
D750iL/D750i=¥32,550 (税込)

 W121.1×H90.3×T16.3mm <b>i356</b>
Front:PORSCHE 911 (3.4L-996)/(3.6L-997)/BOXSTER-S Rear:PORSCHE 911 (3.4L-996)/(3.6L-997)
D300i=¥23,100 (税込)
D550i=¥27,300 (税込)
D750iL/D750i=¥32,550 (税込)

**【注意事項】**形状図と純正装着品が同一寸法かを事前にご確認下さい。

PCCB純正ディスクには使用出来ません。(必ずスチール製ディスクと併用して下さい)また、残量警告センサーの取り付けは出来ません。

注1:パッド品番i150/i153/i159/i254/i257/i258/i350/i351/i355には、残量警告センサーの取り付けが出来ません。