

MercedesBenz

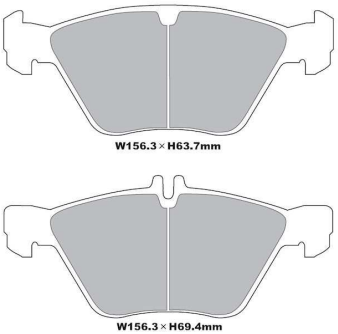

W156.3 x H63.7mm

W156.3 x H69.4mm

**i130**

Front:MercedesBenz W208/W210/R170

D300i=¥16,800 (税込)
D550i=¥21,000 (税込)
D750iL/D750i=¥26,250 (税込)

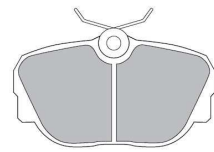

W95 x H52mm

**i131**

Front:MercedesBenz W126

D300i=¥16,800 (税込)
D550i=¥21,000 (税込)
D750iL/D750i=¥26,250 (税込)

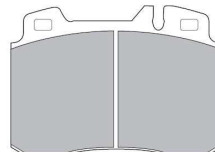

W99.8 x H73.5 x T15.5mm

**i134**

Front:MercedesBenz W124/W201/W210/R129

D300i=¥16,800 (税込)
D550i=¥21,000 (税込)
D750iL/D750i=¥26,250 (税込)

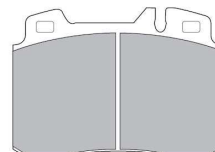

W99.8 x H73.5 x T17.0mm

**i135**

Front:MercedesBenz W124/W201/W210/R129

D300i=¥16,800 (税込)
D550i=¥21,000 (税込)
D750iL/D750i=¥26,250 (税込)



W98 x H84.5mm

**i137**

Front:MercedesBenz W140

D300i=¥16,800 (税込)
D550i=¥21,000 (税込)
D750iL/D750i=¥26,250 (税込)

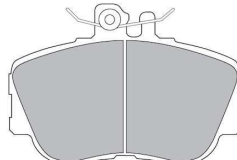

W110 x H74.5mm

**i138**

Front:MercedesBenz W202

D300i=¥16,800 (税込)
D550i=¥21,000 (税込)
D750iL/D750i=¥26,250 (税込)

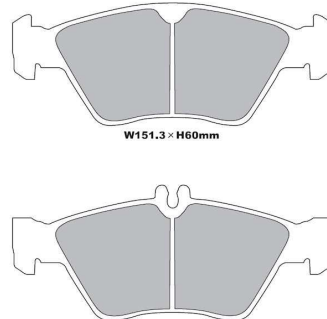

W151.3 x H60mm

W151.3 x H66mm

**i139**

Front:MercedesBenz W202

D300i=¥16,800 (税込)
D550i=¥21,000 (税込)
D750iL/D750i=¥26,250 (税込)



W61.8 x H55mm

**i231**

Rear:MercedesBenz W201/W202

D300i=¥16,800 (税込)
D550i=¥21,000 (税込)
D750iL/D750i=¥26,250 (税込)

MercedesBenz

 W61.8 × H55mm <b>i232</b>
Rear:MercedesBenz W124
<b>D300i=¥16,800 (税込)</b>
<b>D550i=¥21,000 (税込)</b>
<b>D750iL/D750i=¥26,250 (税込)</b>

 W61.5 × H56.5mm <b>i233</b>
Rear:MercedesBenz W126
<b>D300i=¥16,800 (税込)</b>
<b>D550i=¥21,000 (税込)</b>
<b>D750iL/D750i=¥26,250 (税込)</b>

 W61.8 × H58.5mm <b>i234</b>
Rear:MercedesBenz W201/W202/W204/R129/R170
<b>D300i=¥16,800 (税込)</b>
<b>D550i=¥21,000 (税込)</b>
<b>D750iL/D750i=¥26,250 (税込)</b>

 W61.8 × H69.5mm <b>i235</b>
Rear:MercedesBenz W202/W203/W208 W209/W210/W211/W124/W140/R129
<b>D300i=¥16,800 (税込)</b>
<b>D550i=¥21,000 (税込)</b>
<b>D750iL/D750i=¥26,250 (税込)</b>

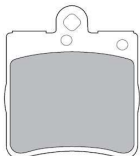
 W63.8 × H72.8mm <b>i236</b>
Rear:MercedesBenz W202/W203/W208/W210/R170
<b>D300i=¥16,800 (税込)</b>
<b>D550i=¥21,000 (税込)</b>
<b>D750iL/D750i=¥26,250 (税込)</b>

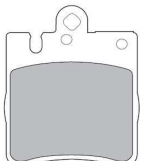
 W63.8 × H78mm <b>i237</b>
Rear:MercedesBenz W203/W209/W210/R171
<b>D300i=¥16,800 (税込)</b>
<b>D550i=¥21,000 (税込)</b>
<b>D750iL/D750i=¥26,250 (税込)</b>

 W63.8 × H63.2mm <b>i238</b>
Rear:MercedesBenz W202
<b>D300i=¥16,800 (税込)</b>
<b>D550i=¥21,000 (税込)</b>
<b>D750iL/D750i=¥26,250 (税込)</b>

 W63.8 × H57.8mm <b>i239</b>
Rear:MercedesBenz W638-ATE
<b>D300i=¥16,800 (税込)</b>
<b>D550i=¥21,000 (税込)</b>
<b>D750iL/D750i=¥26,250 (税込)</b>

MercedesBenz

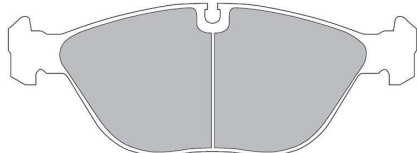

W194.2 × H73.5mm  
**i330**

Front:MercedesBenz W202/W208/W210
D300i=¥18,900 (税込)
D550i=¥23,100 (税込)
D750iL/D750i=¥28,350 (税込)

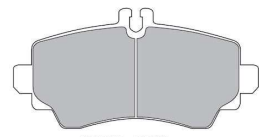

W116.2 × H57.7mm  
**i331**

Front:MercedesBenz W168/W414
D300i=¥16,800 (税込)
D550i=¥21,000 (税込)
D750iL/D750i=¥26,250 (税込)

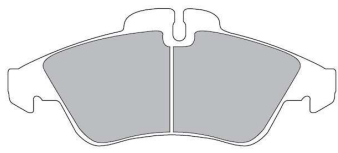

W156.3 × H65mm  
**i332**

Front:MercedesBenz W638-ATE
D300i=¥16,800 (税込)
D550i=¥21,000 (税込)
D750iL/D750i=¥26,250 (税込)

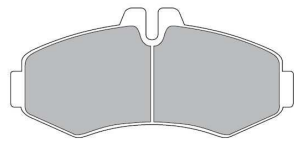

W134 × H64.5mm  
**i333**

Front:MercedesBenz W638-BOSCH
D300i=¥16,800 (税込)
D550i=¥21,000 (税込)
D750iL/D750i=¥26,250 (税込)

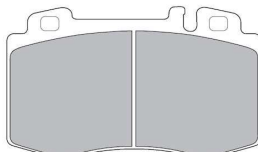

W119.6 × H71.7mm  
**i334**

Front:MercedesBenz W163/W203 W209/W211/W220/R129/R230
D300i=¥18,900 (税込)
D550i=¥23,100 (税込)
D750iL/D750i=¥28,350 (税込)

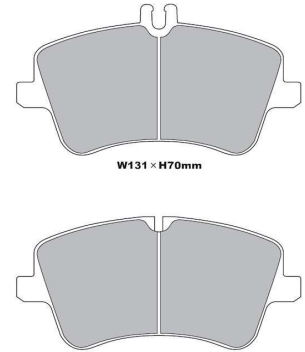

W131 × H70mm  
**i335**  
W131 × H62mm

Front:MercedesBenz W203/W209
D300i=¥16,800 (税込)
D550i=¥21,000 (税込)
D750iL/D750i=¥26,250 (税込)

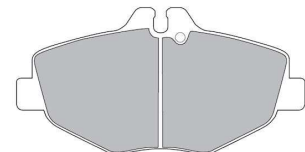

W137 × H67.8mm  
**i336**

Front:MercedesBenz W211
D300i=¥16,800 (税込)
D550i=¥21,000 (税込)
D750iL/D750i=¥26,250 (税込)



W97.5 × H78.5mm  
**i337**

Front:MercedesBenz W211/W220(brembo 8pot)
D300i=¥18,900 (税込)
D550i=¥23,100 (税込)
D750iL/D750i=¥28,350 (税込)

MercedesBenz

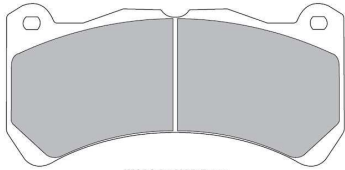

W164.6 × H82.5mm  
**i338**

Front:MercedesBenz R171-SLK55AMG(brembo 6pot)
D300i=¥23,100 (税込)
D550i=¥27,300 (税込)
D750iL/D750i=¥32,550 (税込)



W95.6 × H41.3mm  
**i430**

Rear:MercedesBenz W168/W414
D300i=¥16,800 (税込)
D550i=¥21,000 (税込)
D750iL/D750i=¥26,250 (税込)

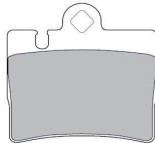

W71 × H68.8mm  
**i431**

Rear:MercedesBenz W220
D300i=¥16,800 (税込)
D550i=¥21,000 (税込)
D750iL/D750i=¥26,250 (税込)

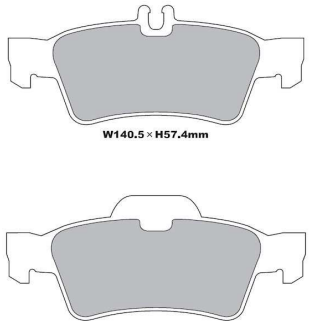

W140.5 × H57.4mm  
**i432**

W141.5 × H59.7mm  
**i432**

Rear:MercedesBenz W211/R230
D300i=¥16,800 (税込)
D550i=¥21,000 (税込)
D750iL/D750i=¥26,250 (税込)



W105 × H52.8mm  
**i433**

Rear:MercedesBenz W638-BOSCH
D300i=¥16,800 (税込)
D550i=¥21,000 (税込)
D750iL/D750i=¥26,250 (税込)



W76.8 × H65.5mm  
**i434**

Rear:MercedesBenz W163
D300i=¥16,800 (税込)
D550i=¥21,000 (税込)
D750iL/D750i=¥26,250 (税込)

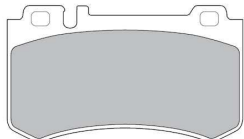

W111.6 × H64.0 × T16.0mm  
**i435**

Rear:MercedesBenz W211/W220(brembo)
D300i=¥18,900 (税込)
D550i=¥23,100 (税込)
D750iL/D750i=¥28,350 (税込)

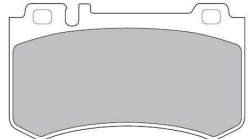

W111.6 × H64.0 × T14.0mm  
**i435b**

Rear:MercedesBenz R171(brembo)
D300i=¥18,900 (税込)
D550i=¥23,100 (税込)
D750iL/D750i=¥28,350 (税込)

MercedesBenz

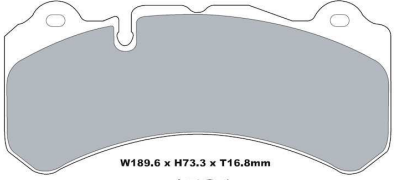

W189.6 x H73.3 x T16.8mm  
**i531**

Front:MercedesBenz R171-SLK350(brembo 6pot)
<b>D300i=¥33,600 (税込)</b>
<b>D550i=¥42,000 (税込)</b>
<b>D750iL/D750i=¥52,500 (税込)</b>

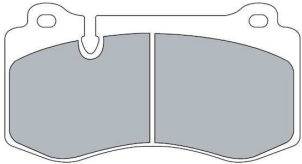

W141.6 x H75.8 x T17.6mm  
**i532**

Front:MercedesBenz R230-SL550/S211-E550
W216-CL550/W221-S350,500,550,600
<b>D300i=¥18,900 (税込)</b>
<b>D550i=¥23,100 (税込)</b>
<b>D750iL/D750i=¥28,350 (税込)</b>

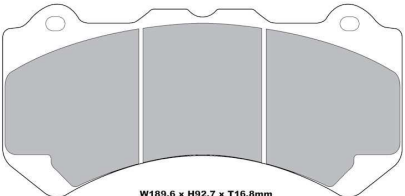

W189.6 x H92.7 x T16.8mm  
**i535**

Front:MercedesBenz W216-AMG CL63/R230-AMG SL55,65
<b>D300i=¥33,600 (税込)</b>
<b>D550i=¥42,000 (税込)</b>
<b>D750iL/D750i=¥52,500 (税込)</b>

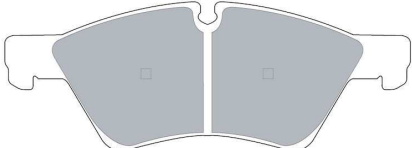

W193.1 x H70.0 x T21.0mm  
**i536**

Front:MercedesBenz W164-ML350,500/W211/S211-E350
<b>D300i=¥23,100 (税込)</b>
<b>D550i=¥27,300 (税込)</b>
<b>D750iL/D750i=¥32,550 (税込)</b>

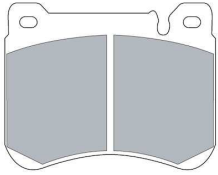

W101.7 x H79.3 x T16.5mm  
**i537**

Front:MercedesBenz R230-C230Kompressor S/P
R171-SLK350
<b>D300i=¥18,900 (税込)</b>
<b>D550i=¥23,100 (税込)</b>
<b>D750iL/D750i=¥28,350 (税込)</b>